

PROGRAMMA MISCELAZIONE BAGNO
BATH MIXING PROGRAM
PROGRAMME DU MITIGEUR POUR LA SALLE DE BAIN
BAD-MISCHUNGSPROGRAMM
PROGRAMA MEZCLADORES BAÑO
ПРОГРАММА СМЕСИТЕЛЕЙ ДЛЯ ВАННОЙ

RETTANGOLO

Art. 20157

Art. 20160

GESSI 

Gessi SpA - Parco Gessi

13037 Serravalle Sesia (Vercelli) - Italy

Phone +39 0163 454111 - Facsimile +39 0163 459273

www.gessi.com - gessi@gessi.it

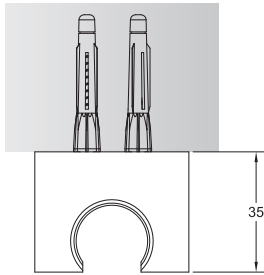
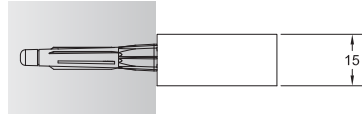
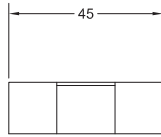

Art. 20157

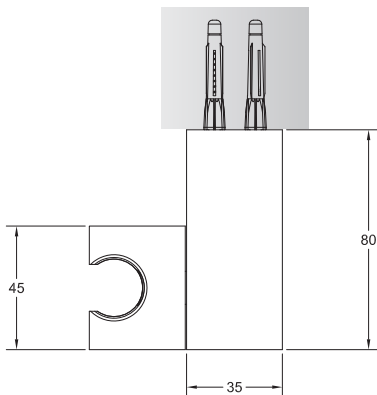
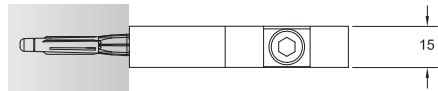
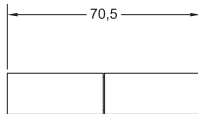

Art. 20160

Prima dell'installazione e messa in funzione

Attenzione! I tubi d'alimentazione devono essere sciacquati con cura prima dell'installazione del dispositivo, in modo che non rimangano trucioli, residui di saldatura o canapa, o altre impurità all'interno dei tubi. Attraverso tubazioni non sciacquate a fondo o attraverso la rete idrica generale, nel dispositivo possono entrare corpi estranei in grado di danneggiare guarnizioni/o-ring.

Si raccomanda pertanto di dotare anche l'impianto generale di filtri.

Before installation and setting to work

Attention! The feeding pipes have to be rinsed carefully before the installation of the device so that there won't remain shavings, sealing or hemp residues, or other impurities inside the pipes. Through pipes not thoroughly rinsed or through the general water network, in the device foreign bodies can enter that could damage gaskets /o-ring.

So filters should be installed also on the general system.

Avant l'installation et la mise en fonction

Attention! Les tuyaux d'alimentation doivent être rincés avec soin avant l'installation du dispositif, de sorte que ils ne restent pas de copeaux, des restes de soudage ou de chanvre, ou d'autres impuretés à l'intérieur des tuyaux. A travers les conduites non rincées à fond ou à travers le réseau hydrique général, dans le dispositif peuvent entrer des corps étrangers à même de détériorer les gaines/o-ring. On recommande ainsi d'installer des filtres également sur le système général.

Vor der Installation und Inbetriebnahme

Achtung! Bevor die Vorrichtung zu installieren, bitte spülen Sie die Zuleitungsröhre sorgfältig aus, um alle Spannen, Schweiß- und Hanfrückstände bzw. alle Verunreinigungen vom Inneren der Röhre zu entfernen. Durch nicht sorgfältig gespülte Rohrleitungen bzw. durch das allgemeine Wassernetz können Fremdkörper in den Korpen eintreten, die die Dichtungen bzw. die O-Ringe beschädigen können. Es ist dann empfehlenswert, die allgemeine Anlage mit Filtern auszustatten.

Antes de la instalación y la puesta en función

¡Cuidado! Los tubos de alimentación tienen que ser enjuagados escrupulosamente antes de instalar el dispositivo de manera que no haya virutas, residuos de soldadura o cáñamo u otras impurezas al interior de los tubos. A través de los tubos no perfectamente enjuagados o de la red hídrica general pueden entrar en el dispositivo unos cuerpos extraños que pueden dañar guarniciones/o-rings.

Les recomendamos por lo tanto que instalen los filtros en la planta general también.

Перед установкой и началом использования

Внимание! Перед установкой устройства необходимо тщательно промыть водопроводные трубы, чтобы в них не оставались стружка, шлак от сварки, лен или другие посторонние тела. Через плохо промытые водопроводные трубы или через общую водопроводную сеть в устройство могут попасть посторонние тела, способные повредить уплотнения и уплотнительные кольца.

Fig. 1

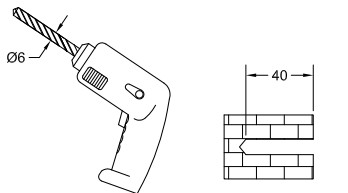
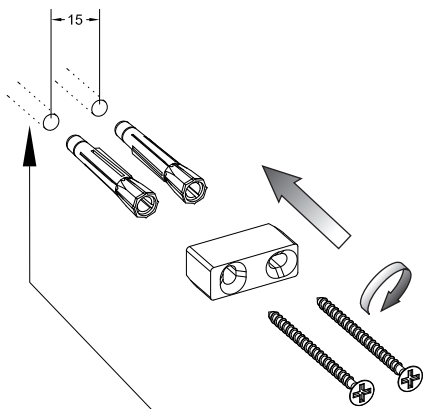

Fig. 2

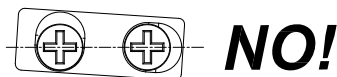
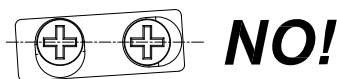
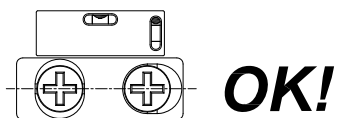

Fig. 3

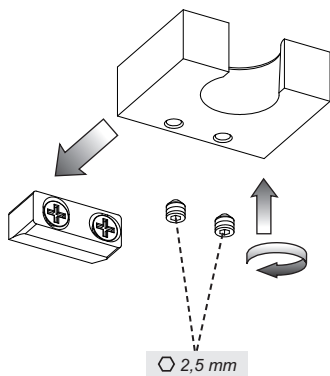

Fig. 4

