



it's a personal experience  
taps | showering | accessories

technical sheet  
product code: PHA-200M/SB-C/P



technical drawing:

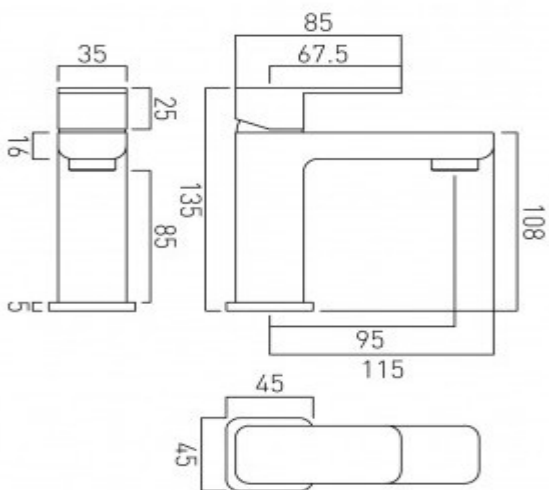

**description:** mini mono basin mixer  
single lever  
deck mounted  
smooth bodied  
without clic-clac waste  
with water flow aerator  
ceramic cartridge PHA-100M-CAR  
2 x 1/2" x 425mm flexipipe connections  
deck mount drill hole diameter 32mm

**finishes:** chrome

**Eco** recommended flow regulator product code: FR-FLEXI/5-PLA

**guarantee:** 12 year guarantee

**minimum operating pressure:** 0.5 bar LP